

General Description

The SP208E-SP213E are enhanced transceivers intended for use in RS-232 and V.28 serial communication. These devices feature very low power consumption and single-supply operation making them ideal for space-constrained applications. MaxLinear on-board charge pump circuitry generates fully compliant RS-232 voltage levels using small and inexpensive 0.1µF charge pump capacitors. External +12V and -12V supplies are not required. The SP211E and SP213E feature a low-power shutdown mode, which reduces power supply drain to 1µA. SP213E includes two receivers that remain active during shutdown to monitor for signal activity.

The SP208E-SP213E devices are pin-to-pin compatible with our previous SP208, SP211 and SP213 as well as industry-standard competitor devices. Driver output and receiver input pins are protected against ESD to over ±15kV for both Human Body Model and IEC61000-4-2 Air Discharge test methods. Data rates of 120kbps are guaranteed, making them compatible with high speed modems and PC remote-access applications. Receivers also incorporate hysteresis for clean reception of slow moving signals.

Ordering Information - [page 20](#)

Features

- Meets all EIA-232 and ITU V.28 specifications
- Single +5V supply operation
- 3mA typical static supply current
- 4 x 0.1µF external charge pump capacitors
- 120kbps transmission rates
- Standard SOIC and SSOP footprints
- 1µA shutdown mode (SP211E & SP213E)
- Two wake-up receivers (SP213E)
- Tri-state / Rx enable (SP211E & SP213E)
- Improved ESD specifications:
 - ±15kV Human Body Model
 - ±15kV IEC6100-4-2 Air Discharge
 - ±8kV IEC6100-4-2 Contact Discharge

Table 1: Model Selection Table

Device	Drivers	Receivers	Pins
SP208E	4	4	24
SP211E	4	5	28
SP213E	4	5	28

Typical Application

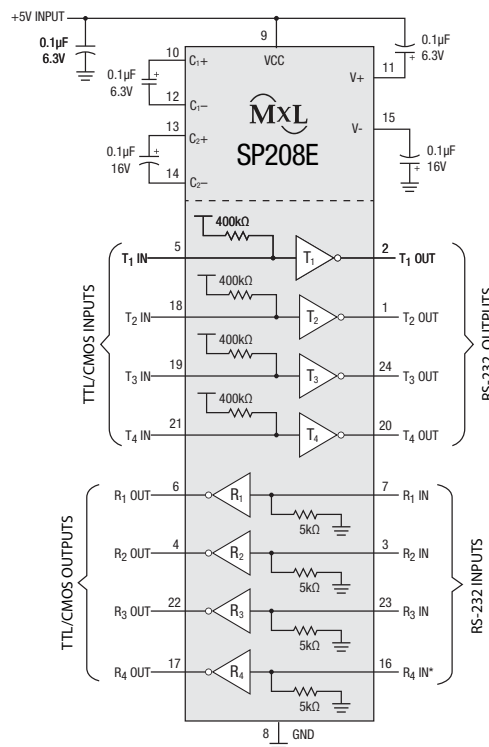

Figure 1: SP208E Typical Application

Revision History

Document No.	Release Date	Change Description
-	01/27/06	Legacy Sipex Datasheet.
1.0.0	07/23/09	Convert to Exar format, update ordering information and change rev to 1.0.0
1.0.1	10/15/12	Change ESD ratings to IEC61000-4-2, remove typical 230kbps data rate reference and update ordering information.
1.0.2	05/15/19	Update to MaxLinear format. Update ordering information. Removed obsolete SP207E. Added ESD rating section after absolute maximums.
2.0.0	10/21/20	Update SP211E and SP213E output voltage swing, RS-232 input voltage range, I_{CC} , maximum storage temperature and absolute maximum R_{IN} voltage. Update Transmitter / Drivers and High Efficient Charge Pumps sections in the Description. Update Transmitter Output graphs for SP211E and SP213E. Update Ordering Information. Changes made in accordance to PCN 20014 (SP211E) and PCN 20015 (SP213E).

Table of Contents

General Description	i
Features	i
Typical Application	i
Specifications	1
Absolute Maximum Ratings.....	1
ESD Ratings.....	1
Electrical Characteristics	2
Pin Information	5
Pin Configurations	5
Description	6
Theory Of Operation.....	6
Transmitter / Drivers.....	6
Receivers	6
Highly Efficient Charge Pump	6
Shutdown Mode	8
SP213E Wakeup Function	8
Shutdown Conditions	8
Receiver Enable	9
ESD Tolerance	10
EIA Standards	12
Typical Application Circuits	12
Mechanical Dimensions	15
SSOP24	15
Mechanical Dimensions	16
WSOIC24	16
Mechanical Dimensions	17
SSOP28	17
Recommended Land Pattern and Stencil	18
SSOP28	18
Mechanical Dimensions	19
WSOIC28	19
Ordering Information	20

List of Figures

Figure 1: SP208E Typical Application	i
Figure 2: SP208E Transmitter Output @ 120kbps $R_L = 3k\Omega$, $C_L = 1000pF$	3
Figure 3: SP208E Transmitter Output @ 120kbps $R_L = 3k\Omega$, $C_L = 2500pF$	3
Figure 4: SP208E Transmitter Output @ 240kbps $R_L = 3k\Omega$, $C_L = 1000pF$	3
Figure 5: SP208E Transmitter Output @ 240kbps $R_L = 3k\Omega$, $C_L = 2500pF$	3
Figure 6: SP211E and SP213E Transmitter Output @ 120kbps $R_L = 3k\Omega$, $C_L = 1000pF$	4
Figure 7: SP211E and SP213E Transmitter Output @ 120kbps $R_L = 3k\Omega$, $C_L = 2500pF$	4
Figure 8: SP211E and SP213E Transmitter Output @ 240kbps $R_L = 3k\Omega$, $C_L = 1000pF$	4
Figure 9: SP211E and SP213E Transmitter Output @ 240kbps $R_L = 3k\Omega$, $C_L = 2500pF$	4
Figure 10: SP208E Pin Configuration	5
Figure 11: SP211E Pin Configuration	5
Figure 12: SP213E Pin Configuration	5
Figure 13: Charge Pump - Phase 1	7
Figure 14: Charge Pump - Phase 2	7
Figure 15: Charge Pump - Phase 3	7
Figure 16: Charge Pump - Phase 4	7
Figure 17: Typical Waveforms Seen on Capacitor C2 When all Drivers are at Maximum Load	8
Figure 18: Wake-Up Timing	9
Figure 19: ESD Test Circuit for Human Body Model	10
Figure 20: ESD Test Circuit for IEC61000-4-2	11
Figure 21: ESD Test Waveform for IEC61000-4-2	11
Figure 22: Typical SP213E Application	12
Figure 23: SP208E Typical Application	13
Figure 24: SP211E Typical Application	13
Figure 25: SP213E Typical Application	14
Figure 26: Mechanical Dimension, SSOP24	15
Figure 27: Mechanical Dimensions, WSOIC24	16
Figure 28: Mechanical Dimensions, SSOP28	17
Figure 29: Recommended Land Pattern and Stencil, SSOP28	18
Figure 30: Mechanical Dimensions, WSOIC28	19

List of Tables

Table 1: Model Selection Table	i
Table 2: Absolute Maximum Ratings	1
Table 3: ESD Ratings	1
Table 4: Electrical Characteristics	2
Table 5: Shutdown and Wake-Up Truth Tables.....	9
Table 6: Transceiver ESD Tolerance Levels	12
Table 7: Ordering Information.....	20

Specifications

Absolute Maximum Ratings

Important: These are stress ratings only and functional operation of the device at these or any other above those indicated in the operation sections of the specification below is not implied. Exposure to absolute maximum ratings conditions for extended periods of time may affect reliability.

Table 2: Absolute Maximum Ratings

Parameter	Minimum	Maximum	Units
V_{CC}		6.0	V
V+	$V_{CC} - 0.3$	13.2	V
V-		13.2	V
Input Voltages			
T_{IN}	-0.3	$V_{CC} + 0.3$	V
R_{IN} , SP208E		± 20	V
R_{IN} , SP211E, SP213E		± 25	V
Output Voltages			
T_{OUT}	V+, 0.3V	V-, -0.3V	V
R_{OUT}	-0.3	$V_{CC} + 0.3$	V
Short Circuit Duration			
T_{out}		Continuous	
Power Dissipation per Package			
24-pin SSOP (derate 11.2mW / °C above +70°C)		900	mW
24-pin SOIC (derate 12.5mW / °C above +70°C)		1000	mW
28-pin SSOP (derate 11.2mW / °C above +70°C)		900	mW
28-pin SOIC (derate 12.7mW / °C above +70°C)		1000	mW

ESD Ratings

Table 3: ESD Ratings

Parameter	Limit	Units
HBM (Human Body Model), Driver Outputs and Receiver Inputs	± 15	kV
IEC61000-4-2 Air Discharge, Driver Outputs and Receiver Inputs	± 15	kV
IEC61000-4-2 Contact Discharge, Driver Outputs and Receiver Inputs	± 8	kV

Electrical Characteristics

V_{CC} at nominal ratings; 0.1 μ F charge pump capacitors; T_{MIN} to T_{MAX} , unless otherwise noted. Typical values are at $V_{CC} = 5V$ and $T_A = 25^\circ C$

Table 4: Electrical Characteristics

Parameter	Test Condition	Minimum	Typical	Maximum	Units	
TTL Inputs T_{IN} , EN, SD						
Logic threshold V_{IL}				0.8	V	
Logic threshold V_{IH}		2.0			V	
Logic pull-up current	$T_{IN} = 0V$		15	200	μA	
Maximum transmission rate	$C_L = 1000pF, R_L = 3k\Omega$	120			kbps	
TTL Outputs						
Compatibility		TTL / CMOS				
V_{OL}	$I_{OUT} = 3.2mA, V_{CC} = 5V$			0.4	V	
V_{OH}	$I_{OUT} = -1.0mA$	3.5			V	
Leakage current	$0V \leq V_{OUT} \leq V_{CC}; SP211E \overline{EN} = 0V;$ $SP213E EN = V_{CC}, T_A = +25^\circ C$		0.05	± 10	μA	
RS-232 Output						
Output voltage swing	SP208E	All transmitter outputs loaded with 3k Ω to ground	± 5	± 7	V	
	SP211E, SP213E	All transmitter outputs loaded with 3k Ω to ground	± 5	± 8.7	V	
Output resistance	$V_{CC} = 0V, V_{OUT} = \pm 2V$	300			Ω	
Output short circuit current	Infinite Duration, $V_{OUT} = 0V$		± 25		mA	
RS-232 Input						
Voltage range	SP208E	$T_A = 25^\circ C$	-15		15	V
	SP211E, SP213E		-25		25	V
Voltage threshold low	$V_{CC} = 5V, T_A = 25^\circ C$	0.8	1.2		V	
Voltage threshold high	$V_{CC} = 5V, T_A = 25^\circ C$		1.7	2.8	V	
Hysteresis	$V_{CC} = 5V$	0.2	0.5	1.0	V	
Resistance	$V_{IN} = \pm 15V, T_A = 25^\circ C$	3	5	7	k Ω	
Dynamic Characteristics						
Driver propagation delay	TTL to RS-232		1.5		μs	
Receiver propagation delay	RS-232 to TTL		0.5	1.5	μs	
Instantaneous slew rate	$C_L = 50pF, R_L = 3 - 7k\Omega, T_A = 25^\circ C,$ from $\pm 3V$			30	V/ μs	
Transition time	$C_L = 2500pF, R_L = 3k\Omega,$ measured from -3V to +3V or +3V to -3V			1.5	μs	
Output enable time			400		ns	
Output disable time			250		ns	

Table 4: Electrical Characteristics

Parameter	Test Condition	Minimum	Typical	Maximum	Units	
Power Requirements						
V_{CC}		4.50	5.00	5.50	V	
I_{CC}	SP208E	No load: $V_{CC} = \pm 10\%$, $T_A = 25^\circ\text{C}$		3	6	mA
	SP211E, SP213E			3	8	
I_{CC}	SP208E	All transmitters $R_L = 3k\Omega$		15		mA
	SP211E, SP213E			23		mA
Shutdown current	$T_A = 25^\circ\text{C}$		1	10	μA	
Environmental and Mechanical						
Operating Temperature	Commercial, _C	0		+70	$^\circ\text{C}$	
	Extended, _E	-40		+85	$^\circ\text{C}$	
Storage temperature		-65		+150	$^\circ\text{C}$	
Package	_A	Shrink (SSOP) small outline				
	_T	Wide (SOIC) small outline				

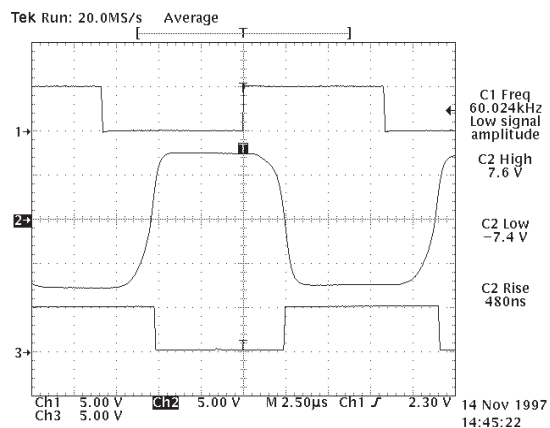

Figure 2: SP208E Transmitter Output @ 120kbps
 $R_L = 3k\Omega$, $C_L = 1000pF$

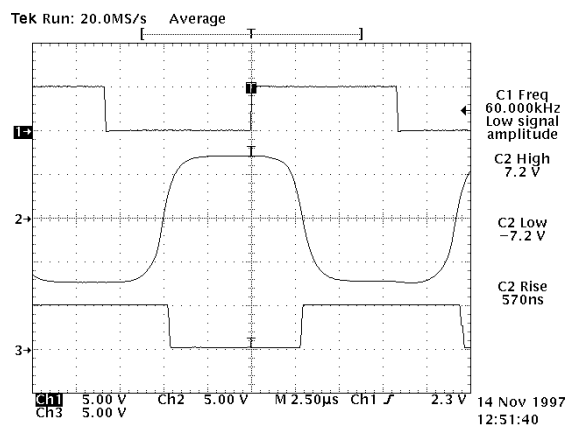

Figure 3: SP208E Transmitter Output @ 120kbps
 $R_L = 3k\Omega$, $C_L = 2500pF$

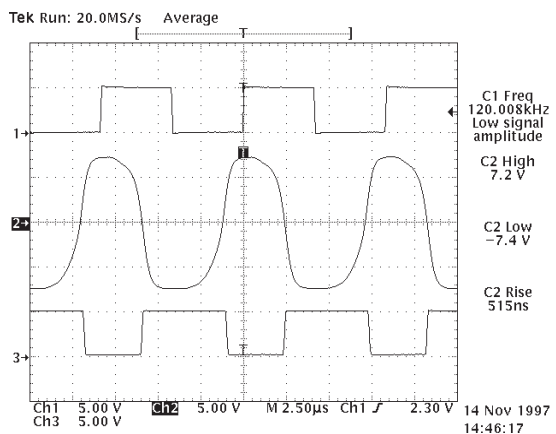

Figure 4: SP208E Transmitter Output @ 240kbps
 $R_L = 3k\Omega$, $C_L = 1000pF$

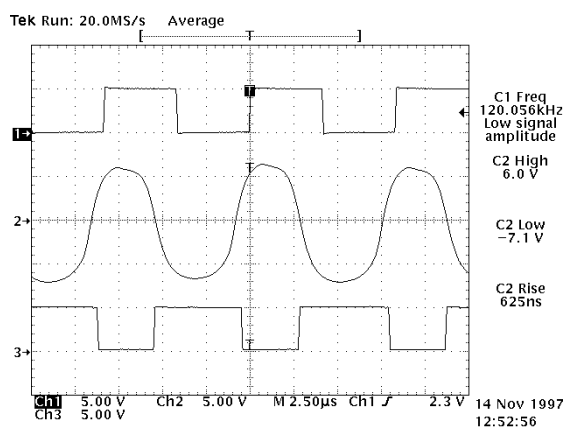

Figure 5: SP208E Transmitter Output @ 240kbps
 $R_L = 3k\Omega$, $C_L = 2500pF$

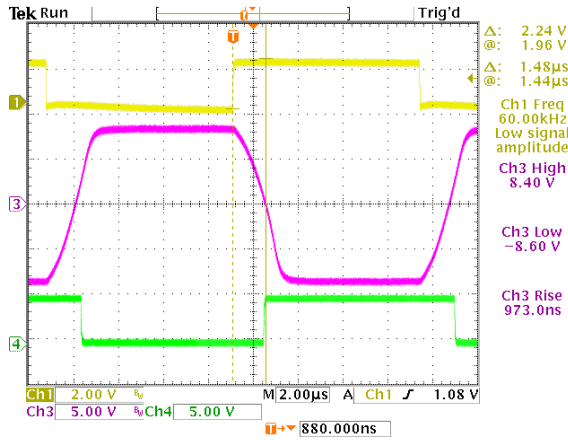

Figure 6: SP211E and SP213E Transmitter Output @ 120kbps $R_L = 3k\Omega$, $C_L = 1000pF$

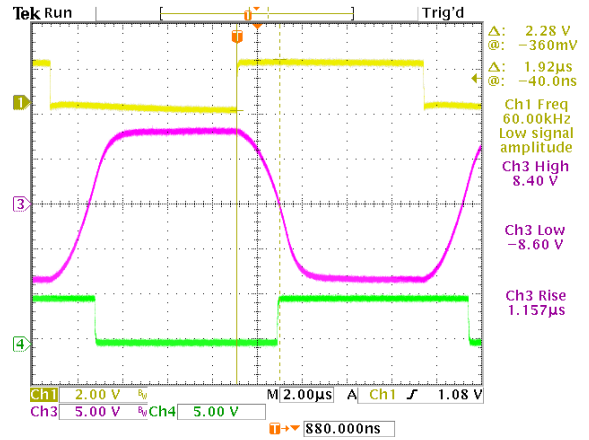

Figure 7: SP211E and SP213E Transmitter Output @ 120kbps $R_L = 3k\Omega$, $C_L = 2500pF$

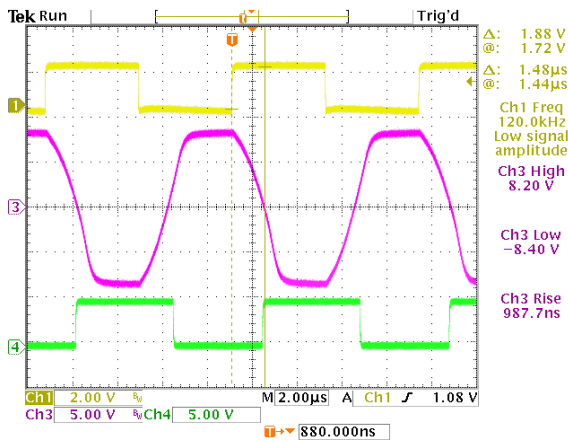

Figure 8: SP211E and SP213E Transmitter Output @ 240kbps $R_L = 3k\Omega$, $C_L = 1000pF$

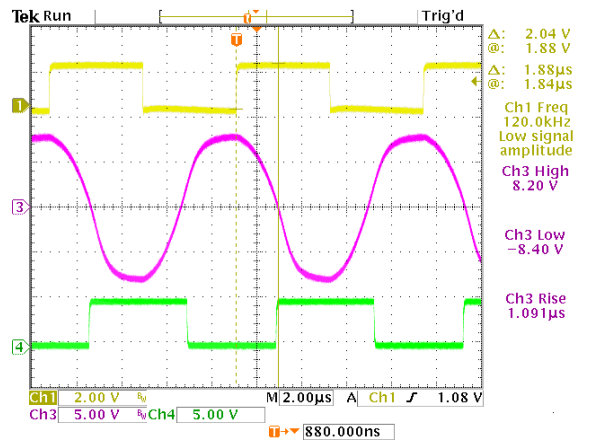

Figure 9: SP211E and SP213E Transmitter Output @ 240kbps $R_L = 3k\Omega$, $C_L = 2500pF$

Pin Information

Pin Configurations

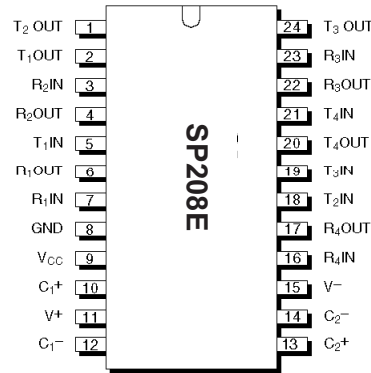

Figure 3: SP208E Pin Configuration

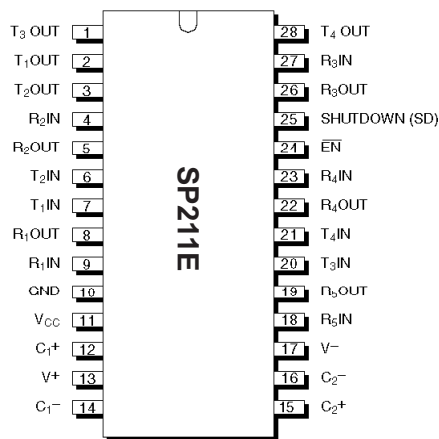

Figure 4: SP211E Pin Configuration

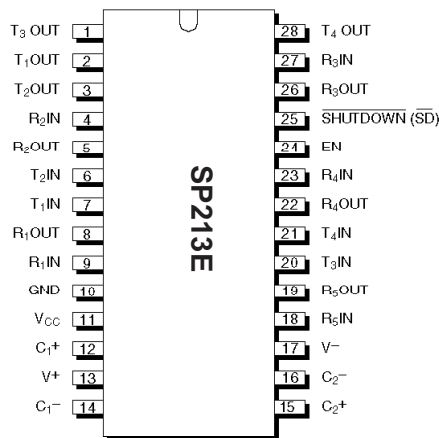

Figure 5: SP213E Pin Configuration

Description

The SP208E, SP211E and SP213E multi-channel transceivers fit most RS-232 / V.28 communication needs. All of these devices feature low-power CMOS construction and MaxLinear on-board charge pump circuitry to generate RS-232 signal-voltages, making them ideal for applications where +9V and -9V supplies are not available. The highly efficient charge pump is optimized to use small and inexpensive 0.1 μ F charge pump capacitors, saving board space and reducing overall circuit cost.

Each device provides a different driver / receiver combination to match standard application requirements. SP208E is a 4-driver/4-receiver device, ideal for providing handshaking signals in V.35 applications or other general-purpose serial communications. The SP211E and SP213E are each 3-driver, 5-receiver devices ideal for DTE serial ports on a PC or other data-terminal equipment.

The SP211E and SP213E feature a low-power shutdown mode, which reduces power supply drain to 1 μ A. The SP213E includes a Wake-Up function which keeps two receivers active in the shutdown mode, unless disabled by the EN pin.

The family is available in 28 and 24 pin SO (wide) and SSOP (shrink) small outline packages. Devices can be specified for commercial (0°C to +70°C) and industrial/extended (-40°C to +85°C) operating temperatures.

Theory Of Operation

MaxLinear RS-232 transceivers contain three basic circuit blocks:

- Transmitter / driver
- Receiver
- Charge pump

SP211E and SP213E also include SHUTDOWN and ENABLE functions.

Transmitter / Drivers

The drivers are single-ended inverting transmitters, which accept either TTL or CMOS inputs and output the RS-232 signals with an inverted sense relative to the input logic levels. Should the input of the driver be left open, an internal pullup to V_{CC} forces the input high, thus committing the output to a logic-1 (MARK) state. The slew rate of the transmitter output is internally limited to a maximum of

30V / μ s in order to meet the EIA / RS-232 and ITU V.28 standards. The transition of the output from high to low also meets the monotonicity requirements of the standard, even when loaded. The transmitter outputs are protected against infinite short-circuits to ground without degradation in reliability.

The drivers of the SP211E, and SP213E can be tri-stated by using the SHUTDOWN function. In this “power-off” state, the charge pump is turned off and V_{CC} current drops to 1 μ A typical. Driver output impedance will remain greater than 300 Ω , satisfying the RS-232 and V.28 specifications. For SP211E, SHUTDOWN is active when pin 25 is driven high. For SP213E, SHUTDOWN is active when pin 25 is driven low.

Receivers

The receivers convert RS-232 level input signals to inverted TTL level signals. Because signals are often received from a transmission line where long cables and system interference can degrade signal quality, the inputs have enhanced sensitivity to detect weakened signals. The receivers also feature a typical hysteresis margin of 500mV for clean reception of slowly transitioning signals in noisy conditions. These enhancements ensure that the receiver is virtually immune to noisy transmission lines.

Receiver input thresholds are between 1.2 to 1.7 volts typical. This allows the receiver to detect standard TTL or CMOS logic-level signals as well as RS-232 signals. If a receiver input is left unconnected or un-driven, a 5k Ω pulldown resistor to ground will commit the receiver to a logic-1 output state.

Highly Efficient Charge Pump

The onboard dual-output charge pump is used to generate positive and negative signal voltages for the RS-232 drivers. This enables fully compliant RS-232 and V.28 signals from a single power supply device.

The charge pumps use four external capacitors to hold and transfer electrical charge. The MaxLinear design uses a unique approach compared to older, less-efficient designs. The pumps use a four-phase voltage shifting technique to attain symmetrical V+ and V- power supplies.

Phase 1 - V_{SS} Charge Store and Double

The positive terminals of capacitors C_1 and C_2 are charged from V_{CC} with their negative terminals initially connected to ground. C_1+ is then connected to ground and the stored charge from C_1- is superimposed onto C_2- . Since C_2+ is still connected to V_{CC} the voltage potential across C_2 is now $2 \times V_{CC}$.

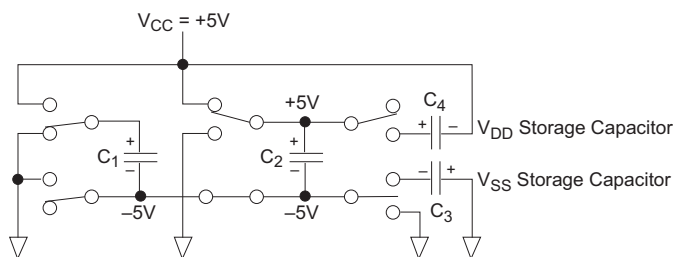

Figure 6: Charge Pump - Phase 1

Phase 2 - V_{SS} Transfer and Invert

Phase two connects the negative terminal of C_2 to the V_{SS} storage capacitor and the positive terminal of C_2 to ground. This transfers the doubled and inverted ($V-$) voltage onto C_3 . Meanwhile, capacitor C_1 is charged from V_{CC} to prepare it for its next phase.

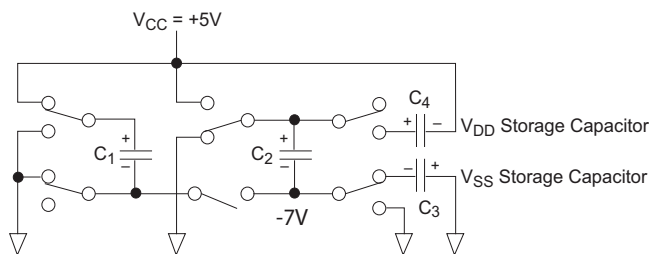

Figure 7: Charge Pump - Phase 2

Phase 3 - V_{DD} Charge Store and Double

Phase three is identical to the first phase. The positive terminals of C_1 and C_2 are charged from V_{CC} with their negative terminals initially connected to ground. C_1+ is then connected to ground and the stored charge from C_1- is superimposed onto C_2- . Since C_2+ is still connected to V_{CC} the voltage potential across capacitor C_2 is now $2 \times V_{CC}$.

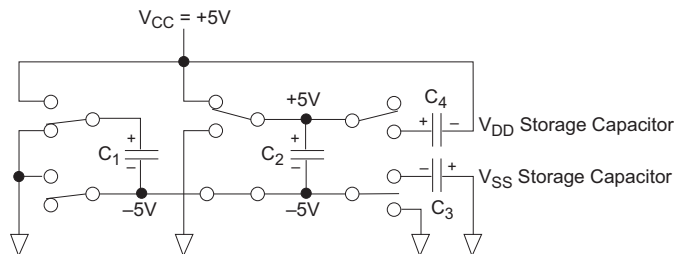

Figure 8: Charge Pump - Phase 3

Phase 4 - V_{DD} Transfer

The fourth phase connects the negative terminal of C_2 to ground and the positive terminal of C_2 to the V_{DD} storage capacitor. This transfers the doubled ($V+$) voltage onto C_4 . Meanwhile, capacitor C_1 is charged from V_{CC} to prepare it for its next phase.

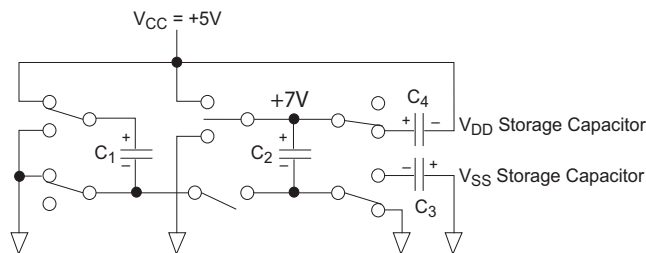

Figure 9: Charge Pump - Phase 4

The MaxLinear charge-pump generates $V+$ and $V-$ independently from V_{CC} . Hence in a no-load condition $V+$ and $V-$ will be symmetrical. Older charge pump approaches generate $V+$ and then use part of that stored charge to generate $V-$. Because of inherent losses, the magnitude of $V-$ will be smaller than $V+$ on these older designs.

The clock rate for the charge pump typically operates at greater than 15kHz, allowing the pump to run efficiently with small 0.1 μ F capacitors. Efficient operation depends on rapidly charging and discharging C_1 and C_2 , therefore capacitors should be mounted close to the IC and have low ESR (equivalent series resistance). Low cost surface mount ceramic capacitors (such as are widely used for power-supply decoupling) are ideal for use on the charge pump.

However the charge pumps are designed to be able to function properly with a wide range of capacitor styles and values. If polarized capacitors are used, the positive and negative terminals should be connected as shown.

Voltage potential across any of the capacitors will never exceed $2 \times V_{CC}$. Therefore capacitors with working voltages as low as 10V rating may be used with a nominal V_{CC} supply. C_1 will never see a potential greater than V_{CC} , so a working voltage of 6.3V is adequate. The reference terminal of the V_{DD} capacitor may be connected either to V_{CC} or ground, but if connected to ground a minimum 16V working voltage is required. Higher working voltages and / or capacitance values may be advised if operating at higher V_{CC} or to provide greater stability as the capacitors age.

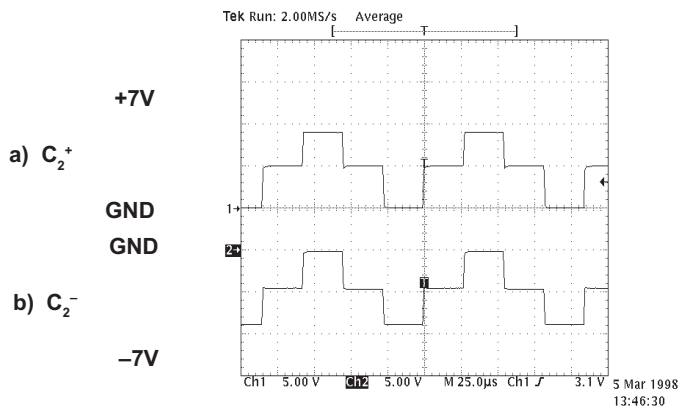

Figure 10: Typical Waveforms Seen on Capacitor C2 When all Drivers are at Maximum Load

Shutdown Mode

SP211E and SP213E feature a control input which will shut down the device and reduce the power supply current to less than $10\mu\text{A}$, making the parts ideal for battery-powered systems. In shutdown mode the transmitters will be tri-stated, the $V+$ output of the charge pump will discharge to V_{CC} and the $V-$ output will discharge to ground. Shutdown will tri-state all receiver outputs of the SP211E.

SP213E Wakeup Function

On the SP213E, shutdown will tri-state receivers 1 - 3. Receivers 4 and 5 remain active to provide a "wake-up" function and may be used to monitor handshaking and control inputs for activity. With only two receivers active during shutdown, the SP213E draws only 5 - $10\mu\text{A}$ of supply current.

Many standard UART devices may be configured to generate an interrupt signal based on changes to the Ring Indicate (RI) or other inputs. A typical application of this function would be to detect modem activity with the computer in a power-down mode. The ring indicator signal from the modem could be passed through an active receiver in the SP213E that is itself in the shutdown mode. The ring indicator signal would propagate through the SP213E to the power management circuitry of the computer to power up the microprocessor and the SP213E drivers. After the supply voltage to the SP213E reaches +5.0V, the SHUTDOWN pin can be disabled, taking the SP213E out of the shutdown mode.

All receivers that are active during shutdown maintain 500mV (typ.) of hysteresis. All receivers on the SP213E may be put into tri-state using the ENABLE pin.

Shutdown Conditions

For complete shutdown to occur and the $10\mu\text{A}$ power drain to be realized, the following conditions must be met:

SP211E:

- +5V must be applied to the SD pin
- ENABLE must be either Ground, +5.0V or not connected
- The transmitter inputs must be either +5.0V or not connected
- V_{CC} must be +5V
- Receiver inputs must be $>0\text{V}$ and $<+5\text{V}$

SP213E:

- 0V must be applied to the SD pin
- ENABLE must be either 0V, +5.0V or not connected
- The transmitter inputs must be either +5.0V or not connected
- V_{CC} must be +5V
- Receiver inputs must be $>0\text{V}$ and $<+5\text{V}$

Receiver Enable

SP211E and SP213E feature an enable input, which allows the receiver outputs to be either tri-stated or enabled. This can be especially useful when the receiver is tied directly to a shared microprocessor data bus. For the SP211E, enable is active low; that is, 0V applied to the ENABLE pin will enable the receiver outputs. For the SP213E, enable is active high; that is, +5V applied to the ENABLE pin will enable the receiver outputs.

Table 5: Shutdown and Wake-Up Truth Tables

SP211E				
SD	EN#	Drivers	Receivers	
0	1	Active	Tri-state	
0	0	Active	Active	
1	1	Off	Tri-state	
1	0	Off	Tri-state	

SP213E				
SD#	EN	Drivers	RX 1-3	RX 4-5
0	1	Off	Tri-state	Active
0	0	Off	Tri-state	Tri-state
1	1	Active	Active	Active
1	0	Active	Tri-state	Tri-state

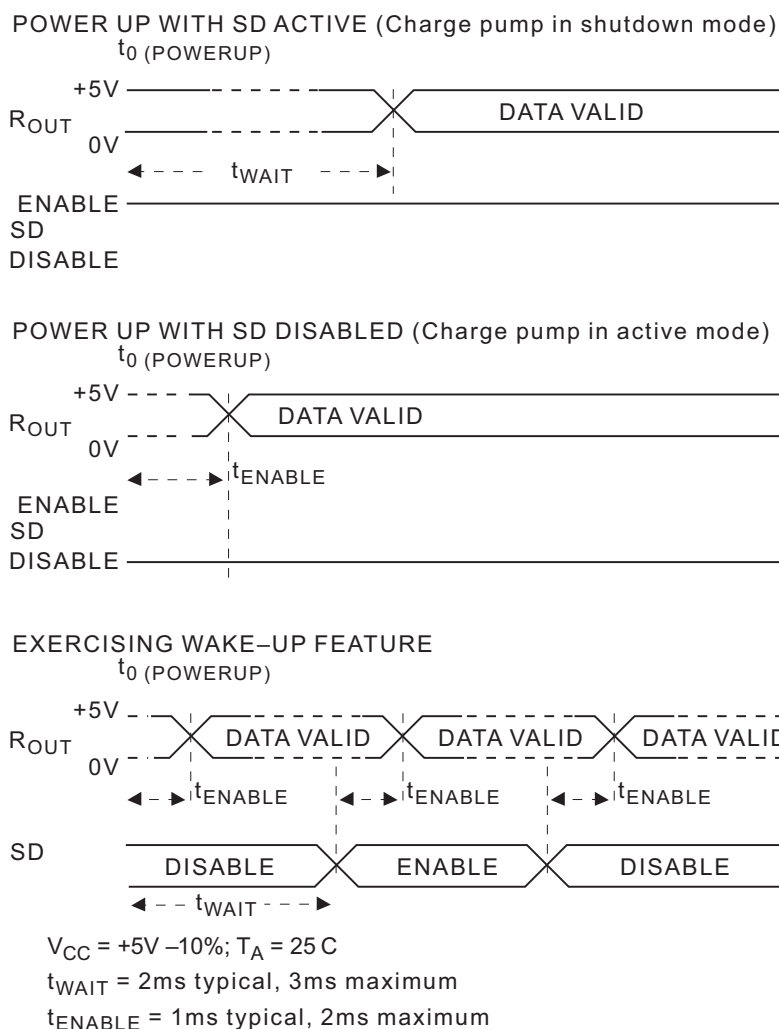

Figure 11: Wake-Up Timing

ESD Tolerance

The SP208E, SP211E and SP213E devices incorporate ruggedized ESD cells on all driver output and receiver input pins. The ESD structure is improved over our previous family for more rugged applications and environments sensitive to electro-static discharges and associated transients. The improved ESD tolerance is at least $\pm 15\text{kV}$ without damage nor latch-up.

There are different methods of ESD testing applied:

- a) MIL-STD-883, Method 3015.7
- b) IEC61000-4-2 Air Discharge
- c) IEC61000-4-2 Direct Contact

The Human Body Model has been the generally accepted ESD testing method for semiconductors. This method is also specified in MIL-STD-883, Method 3015.7 for ESD testing. The premise of this ESD test is to simulate the human body's potential to store electro-static energy and discharge it to an integrated circuit. The simulation is performed by using a test model as shown in [Figure 12](#). This method will test the IC's capability to withstand an ESD transient during normal handling such as in manufacturing areas where the IC's tend to be handled frequently.

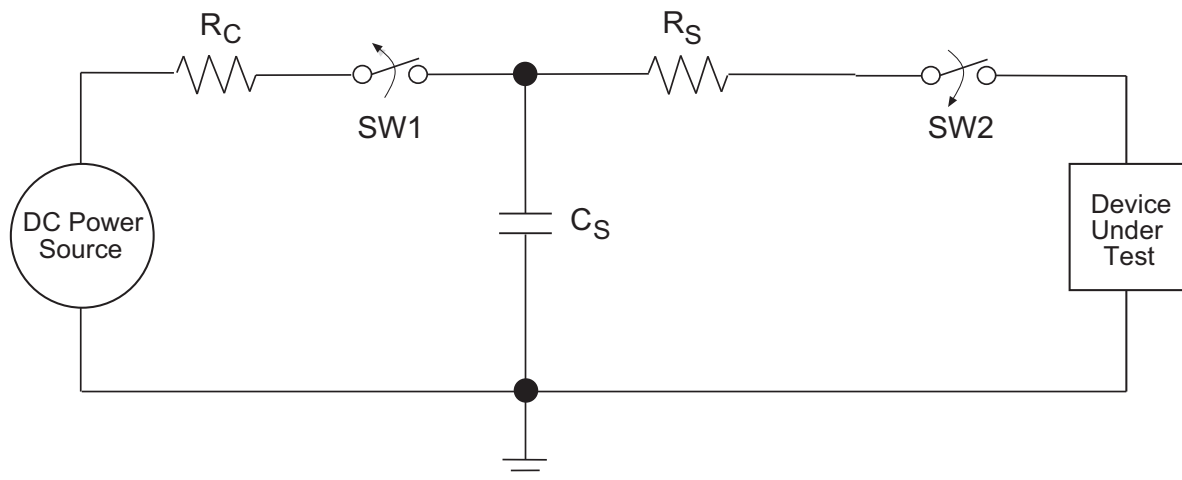

Figure 12: ESD Test Circuit for Human Body Model

The IEC-61000-4-2, formerly IEC801-2, is generally used for testing ESD on equipment and systems. System manufacturers must guarantee a certain amount of ESD protection since the system itself is exposed to the outside environment and human presence. The premise with IEC61000-4-2 is that the system is required to withstand an amount of static electricity when ESD is applied to points and surfaces of the equipment that are accessible to personnel during normal usage. The transceiver IC receives most of the ESD current when the ESD source is applied to the connector pins. The test circuit for IEC61000-4-2 is shown on [Figure 13](#). There are two methods within IEC61000-4-2, the Air Discharge method and the Contact Discharge method.

With the Air Discharge Method, an ESD voltage is applied to the equipment under test (EUT) through air. This simulates an electrically charged person ready to connect a

cable onto the rear of the system only to find an unpleasant zap just before the person touches the back panel. The high energy potential on the person discharges through an arcing path to the rear panel of the system before he or she even touches the system. This energy, whether discharged directly or through air, is predominantly a function of the discharge current rather than the discharge voltage. Variables with an air discharge such as approach speed of the object carrying the ESD potential to the system and humidity will tend to change the discharge current. For example, the rise time of the discharge current varies with the approach speed.

The Contact Discharge Method applies the ESD current directly to the EUT. This method was devised to reduce the unpredictability of the ESD arc. The discharge current rise time is constant since the energy is directly transferred without the air-gap arc.

In situations such as hand held systems, the ESD charge can be directly discharged to the equipment from a person already holding the equipment. The current is transferred on to the keypad or the serial port of the equipment directly and then travels through the PCB and finally to the IC.

The circuit model in **Figure 12** and **Figure 13** represent the typical ESD testing circuit used for all three methods. The C_S is initially charged with the DC power supply when the first switch (SW1) is on.

Now that the capacitor is charged, the second switch (SW2) is on while SW1 switches off. The voltage stored in the capacitor is then applied through R_S , the current limiting resistor, onto the device under test (DUT). In ESD tests, the SW2 switch is pulsed so that the device under test receives a duration of voltage.

For the Human Body Model, the current limiting resistor (R_S) and the source capacitor (C_S) are 1.5k Ω and 100pF, respectively. For IEC61000-4-2, the current limiting resistor (R_S) and the source capacitor (C_S) are 330 Ω and 150pF, respectively.

The higher C_S value and lower R_S value in the IEC61000-4-2 model are more stringent than the Human Body Model. The larger storage capacitor injects a higher voltage to the test point when SW2 is switched on. The lower current limiting resistor increases the current charge onto the test point.

The larger storage capacitor injects a higher voltage to the test point when SW2 is switched on. The lower current limiting resistor increases the current charge onto the test point.

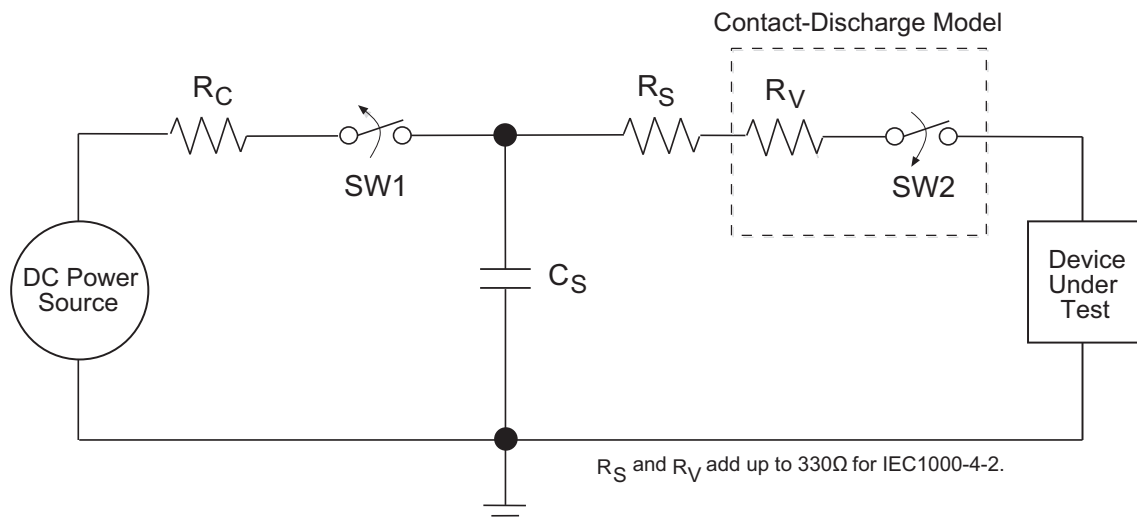

Figure 13: ESD Test Circuit for IEC61000-4-2

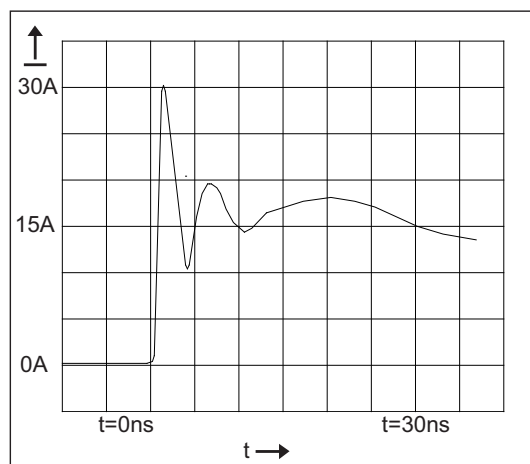

Figure 14: ESD Test Waveform for IEC61000-4-2

The RS-232 is a relatively slow data exchange protocol, with a maximum baud rate of only 20kbps, which can be transmitted over a maximum copper wire cable length of 50 feet. The SP208E, SP211E and SP213E data communications interface products have been designed to meet both the EIA protocol standards, and the needs of the industry.

EIA Standards

The Electronic Industry Association (EIA) developed several standards of data transmission which are revised and updated in order to meet the requirements of the industry. In data processing, there are two basic means of communicating between systems and components. The RS-232 standard was first introduced in 1962 and, since that time, has become an industry standard.

Table 6: Transceiver ESD Tolerance Levels

Device Pin Tested	Human Body Model	IEC61000-4-2		
		Air Discharge	Direct Contact	Level
Driver Outputs	±15kV	±15kV	±8kV	4
Receiver Inputs	±15kV	±15kV	±8kV	4

Typical Application Circuits

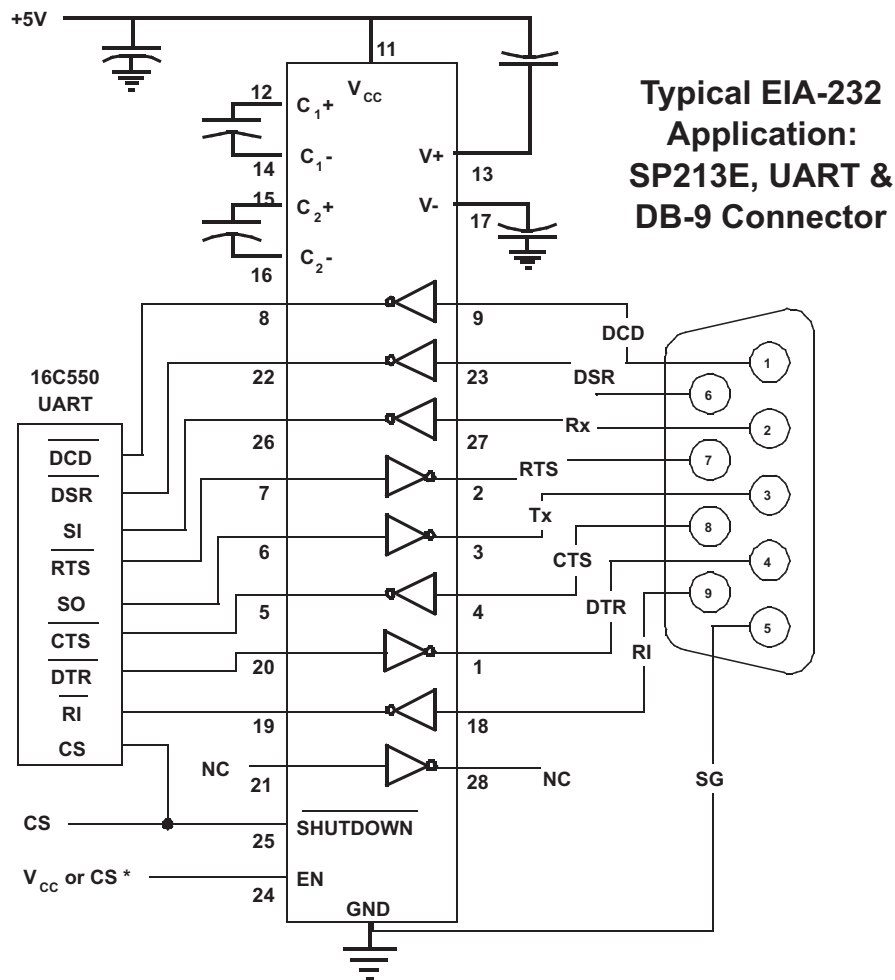

Figure 15: Typical SP213E Application

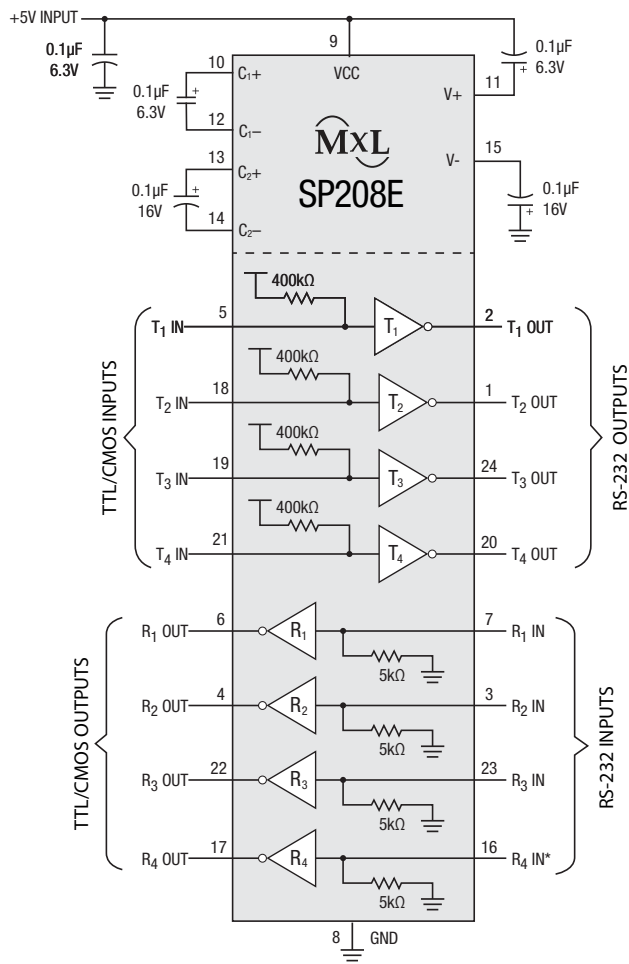

Figure 16: SP208E Typical Application

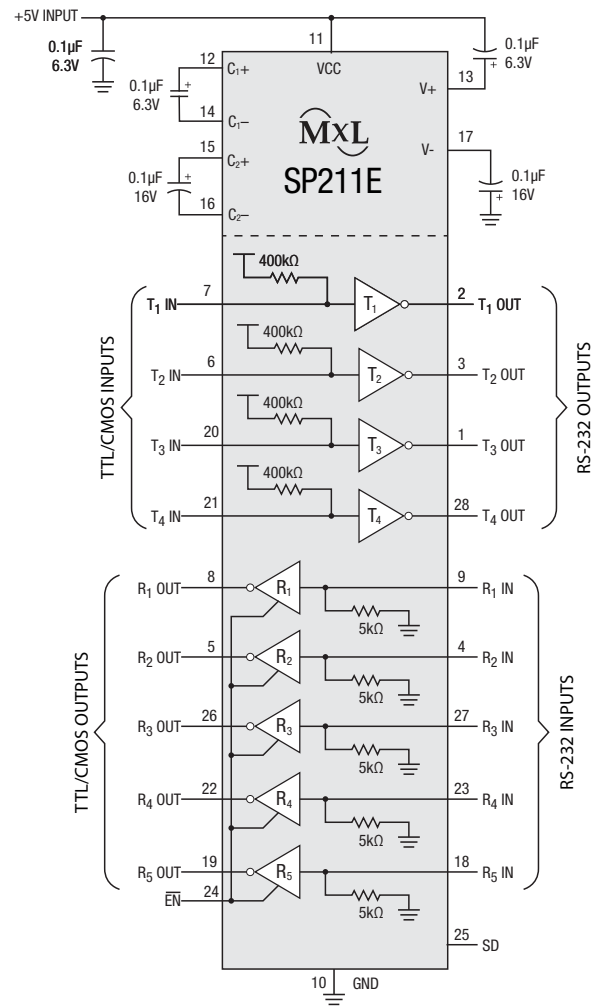

Figure 17: SP211E Typical Application

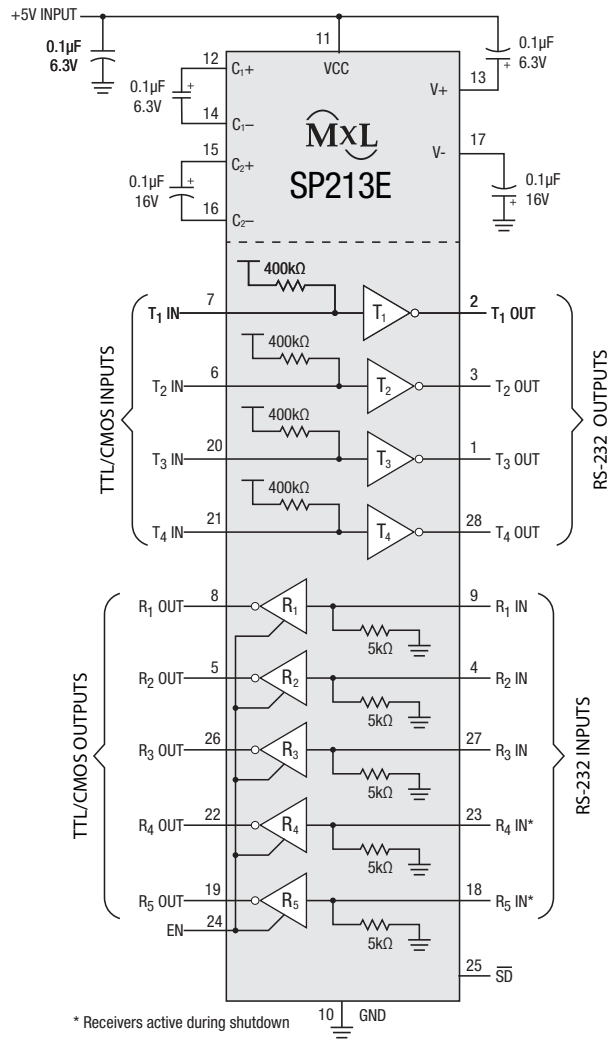
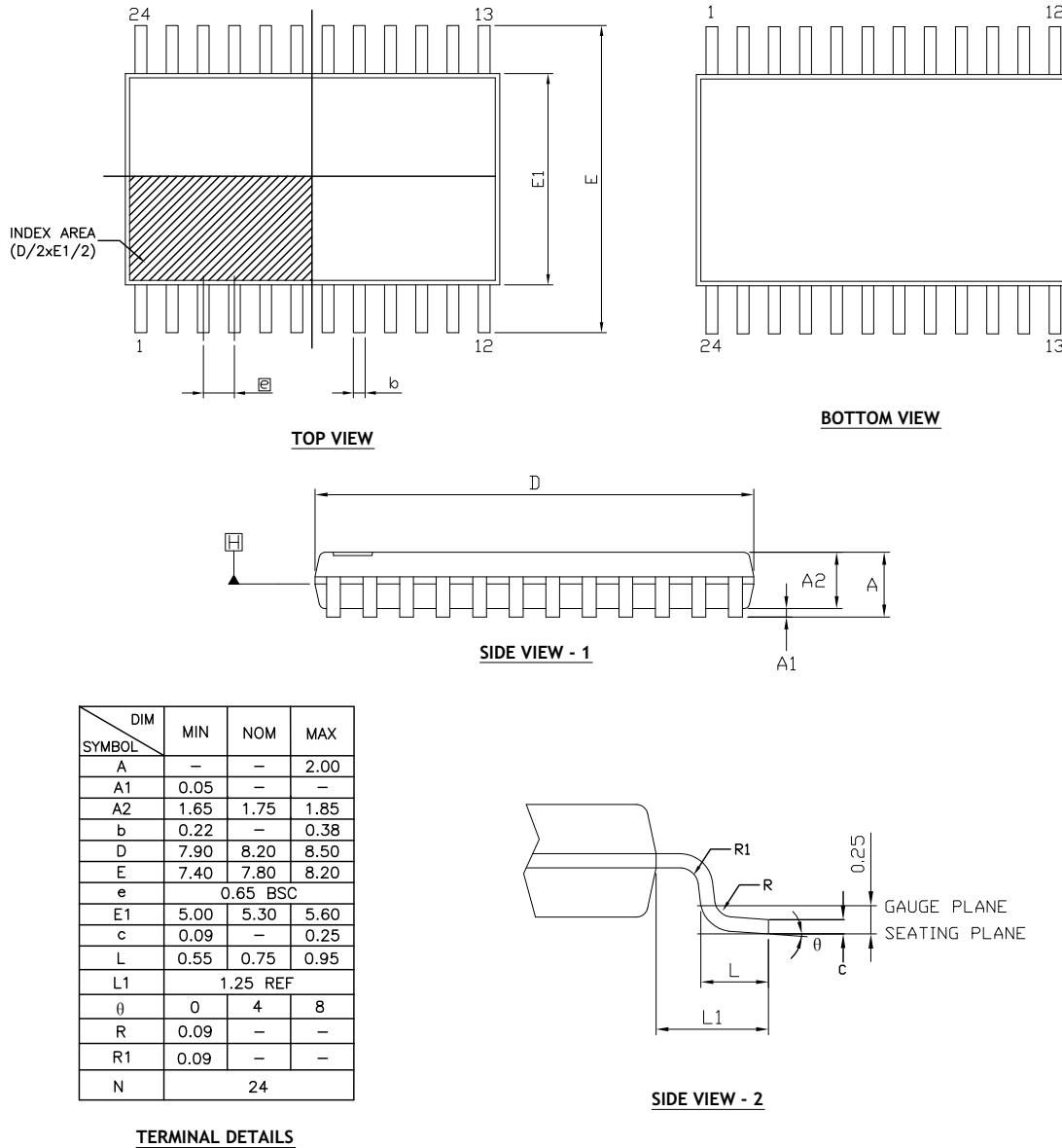

Figure 18: SP213E Typical Application

Mechanical Dimensions

SSOP24



- ALL DIMENSIONS ARE IN MILLIMETERS, ANGLES ARE IN DEGREES.
- DIMENSIONS AND TOLERANCE PER JEDEC MO-150.

Drawing No.: POD-00000148

Revision: A

Figure 19: Mechanical Dimension, SSOP24

Mechanical Dimensions

WSOIC24

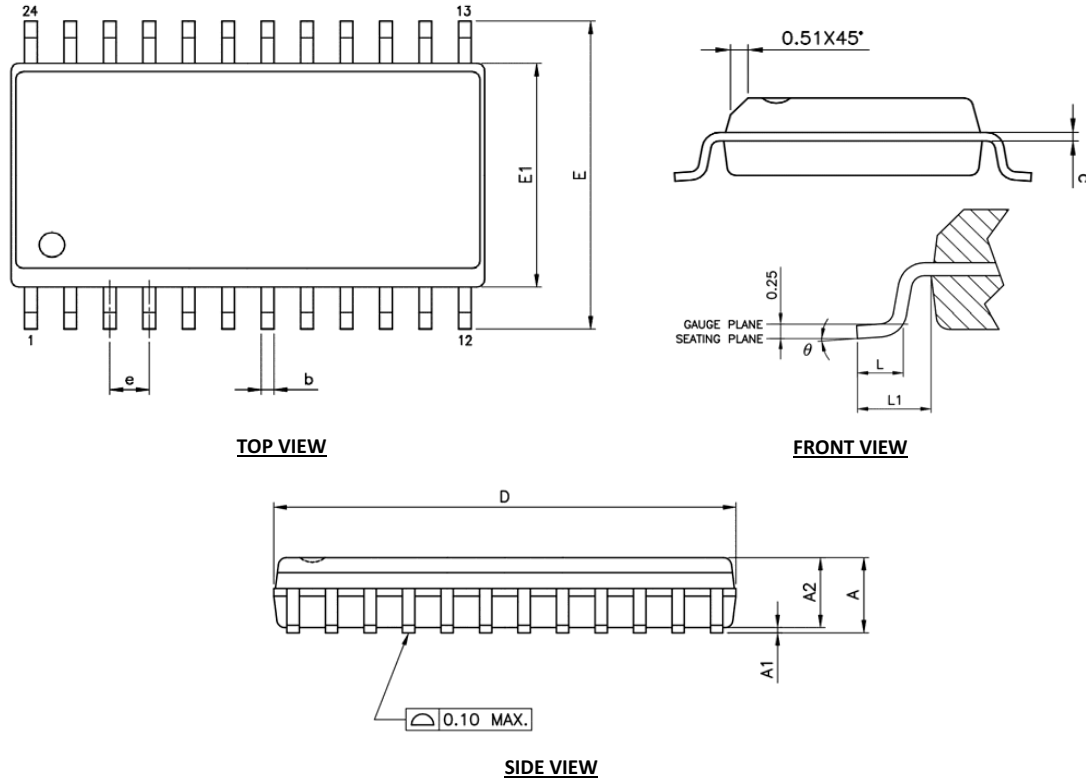

SYMBOLS	MIN.	NOM.	MAX.
A	—	—	2.65
A1	0.10	—	0.30
A2	2.05	—	—
b	0.31	—	0.51
c	0.20	—	0.33
D	15.24	—	15.70
E1	7.50 BSC		
E	10.30 BSC		
e	1.27 BSC		
L1	1.40 REF		
L	0.40	—	1.27
θ	0°	—	8°

TERMINAL DETAILS

1. All dimensions are in Millimeters
2. Dimensions and tolerance per Jedec MS-013 AD

Drawing No. : POD - 00000122

Revision: A

Figure 20: Mechanical Dimensions, WSOIC24

Mechanical Dimensions

SSOP28

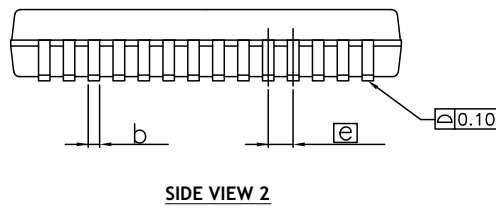
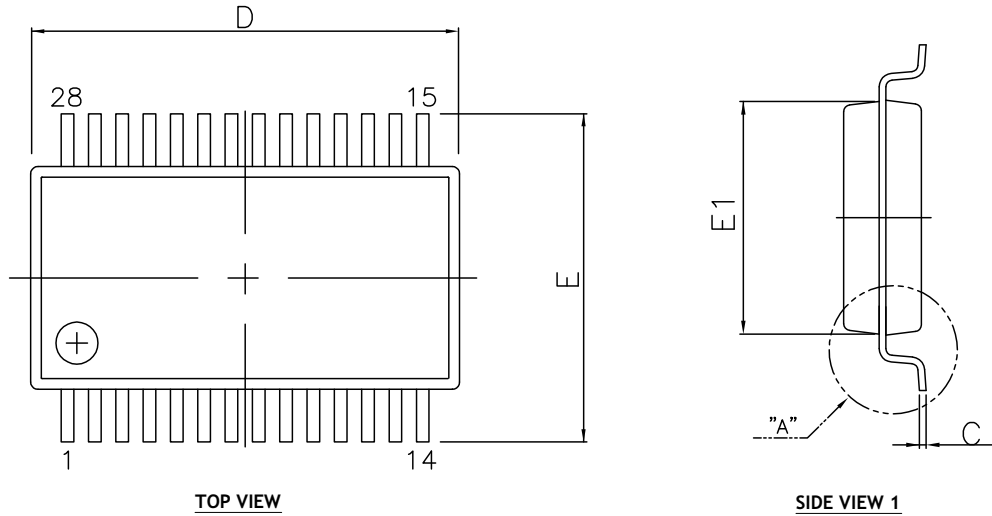

DIM SYMBOL	MIN	NOM	MAX
A	-	-	2.00
A1	0.05	-	-
A2	1.65	1.75	1.85
b	0.22	-	0.38
L1	1.25 REF		
L2	0.25 BSC		
e	0.65 BSC		
c	0.09	-	0.25
E	7.40	7.80	8.20
E1	5.00	5.30	5.60
L	0.55	0.75	0.95
R	0.09	-	-
θ	0	4	8
D	9.90	10.20	10.50
N	28		

TERMINAL DETAILS

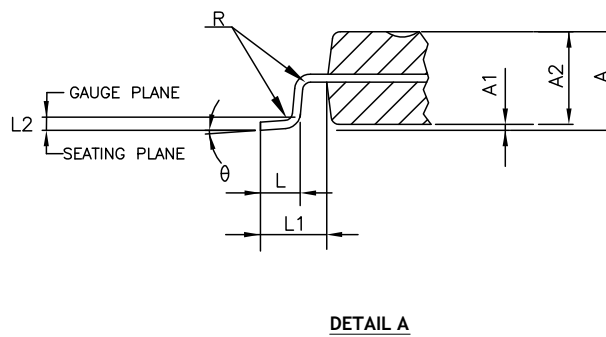

- ALL DIMENSIONS ARE IN MILLIMETERS, ANGLES ARE IN DEGREES.
- DIMENSIONS AND TOLERANCE PER JEDEC MO-150 AH.

Drawing No.: POD-000000 133

Revision: A

Figure 21: Mechanical Dimensions, SSOP28

Recommended Land Pattern and Stencil

SSOP28

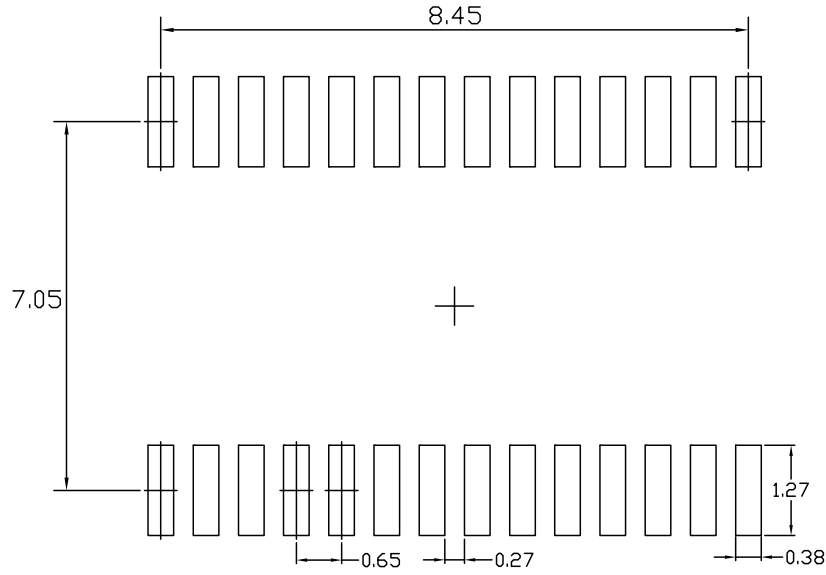

TYPICAL RECOMMENDED LAND PATTERN

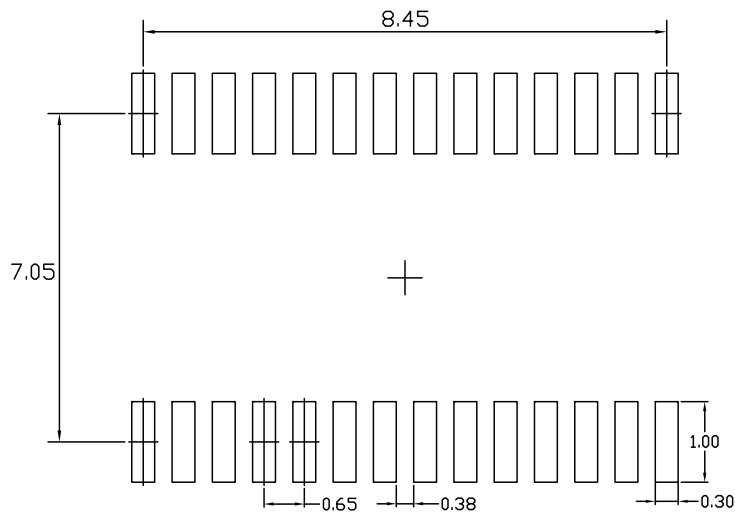

TYPICAL RECOMMENDED STENCIL

Drawing No.: POD-000000 133

Revision: A

Figure 22: Recommended Land Pattern and Stencil, SSOP28

Mechanical Dimensions

WSOIC28

Top View

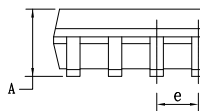
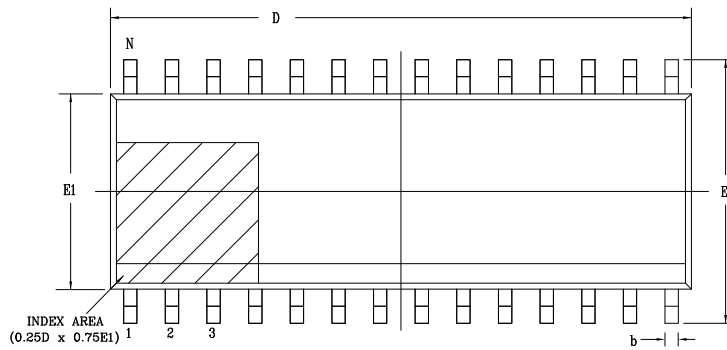

Side View

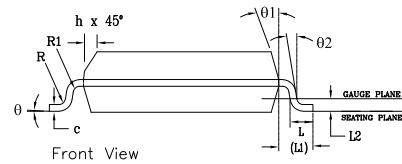

Front View

PACKAGE OUTLINE SOIC .300" BODY JEDEC MS-013 VARIATION AE						
SYMBOLS	COMMON DIMENSIONS IN MM (Control Unit)			COMMON DIMENSIONS IN INCHES (Reference Unit)		
	MIN	NOM	MAX	MIN	NOM	MAX
A	2.35	—	2.65	0.093	—	0.104
A1	0.10	—	0.30	0.004	—	0.012
A2	2.05	—	2.55	0.081	—	0.100
b	0.31	—	0.51	0.012	—	0.020
c	0.20	—	0.33	0.008	—	0.013
E	10.30 BSC			0.406 BSC		
E1	7.50 BSC			0.295 BSC		
e	1.27 BSC			0.050 BSC		
h	0.25	—	0.75	0.010	—	0.030
L	0.40	—	1.27	0.016	—	0.050
L1	1.40 REF			0.055 REF		
L2	0.25 BSC			0.010 BSC		
R	0.07	—	—	0.003	—	—
R1	0.07	—	—	0.003	—	—
θ	0°	—	8°	0°	—	8°
θ1	5°	—	15°	5°	—	15°
θ2	0°	—	—	0°	—	—
D	17.90 BSC			0.705 BSC		
N	28					

Drawing No: POD-00000106
Revision: B

Figure 23: Mechanical Dimensions, WSOIC28

Ordering Information

Table 7: Ordering Information⁽¹⁾

Ordering Part Number	Drivers	Receivers	Operating Temperature Range	Package	Lead-Free ⁽²⁾	Packaging Method
SP208E						
SP208ECA-L/TR	4	4	0°C to 70°C	SSOP24	Yes	Reel
SP208EEA-L/TR	4	4	-40°C to 85°C	SSOP24	Yes	Reel
SP208EET-L/TR	4	4	-40°C to 85°C	WSOIC24	Yes	Reel
SP211E						
SP211ECA-L/TR	4	5	0°C to 70°C	SSOP28	Yes	Reel
SP211ECT-L/TR	4	5	0°C to 70°C	WSOIC28	Yes	Reel
SP211EEA-L/TR	4	5	-40°C to 85°C	SSOP28	Yes	Reel
SP213E						
SP213ECA-L/TR	4	5 ⁽³⁾	0°C to 70°C	SSOP28	Yes	Reel
SP213EEA-L/TR	4	5 ⁽³⁾	-40°C to 85°C	SSOP28	Yes	Reel

1. Refer to www.maxlinear.com/SP208E, www.maxlinear.com/SP211E, and www.maxlinear.com/SP213E for most up-to-date Ordering Information.

2. Visit www.maxlinear.com for additional information on Environmental Rating.

3. With 2 active receivers in shutdown.



MaxLinear, Inc.
5966 La Place Court, Suite 100
Carlsbad, CA 92008
760.692.0711 p.
760.444.8598 f.
www.maxlinear.com

The content of this document is furnished for informational use only, is subject to change without notice, and should not be construed as a commitment by MaxLinear, Inc. MaxLinear, Inc. assumes no responsibility or liability for any errors or inaccuracies that may appear in the informational content contained in this guide. Complying with all applicable copyright laws is the responsibility of the user. Without limiting the rights under copyright, no part of this document may be reproduced into, stored in, or introduced into a retrieval system, or transmitted in any form or by any means (electronic, mechanical, photocopying, recording, or otherwise), or for any purpose, without the express written permission of MaxLinear, Inc.

MaxLinear, Inc. does not recommend the use of any of its products in life support applications where the failure or malfunction of the product can reasonably be expected to cause failure of the life support system or to significantly affect its safety or effectiveness. Products are not authorized for use in such applications unless MaxLinear, Inc. receives, in writing, assurances to its satisfaction that: (a) the risk of injury or damage has been minimized; (b) the user assumes all such risks; (c) potential liability of MaxLinear, Inc. is adequately protected under the circumstances.

MaxLinear, Inc. may have patents, patent applications, trademarks, copyrights, or other intellectual property rights covering subject matter in this document. Except as expressly provided in any written license agreement from MaxLinear, Inc., the furnishing of this document does not give you any license to these patents, trademarks, copyrights, or other intellectual property.

MaxLinear, the MaxLinear logo, and any MaxLinear trademarks, MxL, Full-Spectrum Capture, FSC, G.now, AirPHY, Puma, AnyWAN and the MaxLinear logo are all on the products sold, are all trademarks of MaxLinear, Inc. or one of MaxLinear's subsidiaries in the U.S.A. and other countries. All rights reserved. Other company trademarks and product names appearing herein are the property of their respective owners.

Mouser Electronics

Authorized Distributor

Click to View Pricing, Inventory, Delivery & Lifecycle Information:

MaxLinear:

[SP213ECA-L](#) [SP208ECA-L](#) [SP211EET-L](#) [SP211ECA-L](#) [SP211EEA-L](#) [SP208EEA-L](#) [SP208EET-L](#) [SP211ECT-L](#)
[SP211ECA-L/TR](#) [SP208EET-L/TR](#) [SP211EEA-L/TR](#) [SP211ECT-L/TR](#) [SP213EEA-L](#) [SP213EEA-L/TR](#) [SP211EET-](#)
[L/TR](#) [SP208ECT-L](#) [SP208ECT-L/TR](#) [SP208EEA-L/TR](#) [SP213ECA-L/TR](#) [SP208ECA-L/TR](#)